

KM1800B

Temperature and humidity sensor

User Manual

File Version: V23.6.17



KM1800B using the standard ,easy access to PLC, DCS and other instruments or systems for monitoring 温 humidity state quantities.The internal use of high-precision sensing core and related devices to ensure high reliability and excellent long-term stability,can be customized RS232,RS485,CAN,4-20mA,DC0~5V/10V,ZIGBEE,Lora,WIFI,GPRS and other output methods.

Technical Parameters

Technical parameter	Parameter value
Brand	KLHA
Power	DC12~24V 1A
Running temperature	-30~85°C
Working humidity	5%RH~90%RH

Product Size

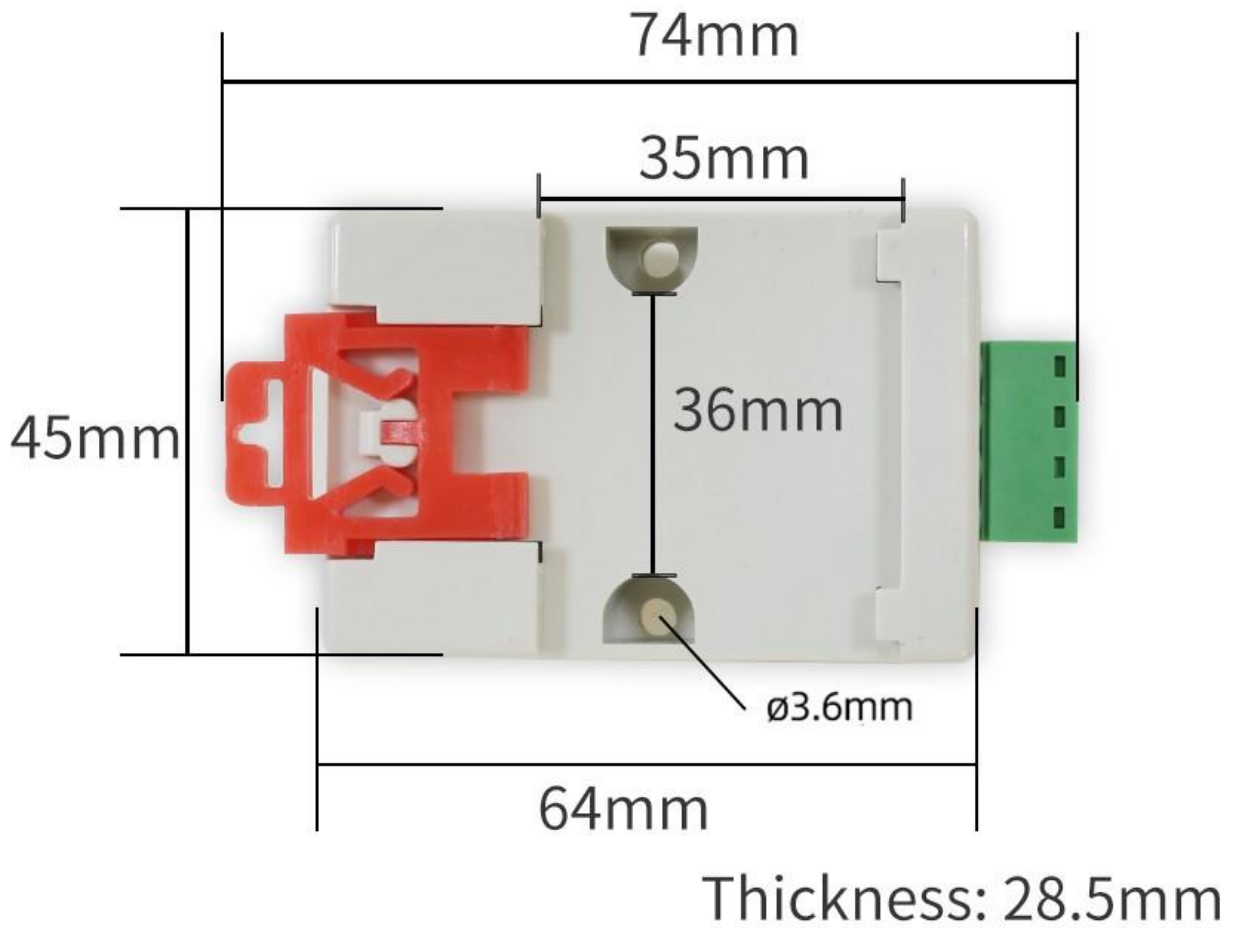

1. READ DATA (FUNCTION CODE 0X03)

INQUIRY FRAME (HEXADECIMAL), SENDING EXAMPLE: QUERY 1# DEVICE 1 DATA, HOST COMPUTER SEND COMMAND: 01 03 00 00 00 02 C4 0B 。

Address	Function code	Start address	Data length	Checksum
01	03	00 00	00 02	C4 0B

FOR THE CORRECT QUERY FRAME, THE DEVICE RESPONDS WITH DATA: 01 03 04 00 7A 00 00 DB EA IN THE FOLLOWING FORMAT:

Address	Function code	Start address	Data length	Checksum
01	03	04	00 79	DB EA

2. COMMON DATA ADDRESS TABLE

CONFIGURATION ADDRESS	REGISTER ADDRESS	REGISTER DESCRIPTION	DATA TYPE	VALUE RANGE
40001	00 00	1#TEMPERATURE REGISTER	READ ONLY	0~65535
40002	00 01	2#TEMPERATURE REGISTER	READ ONLY	0~65535
40101	00 64	MODEL NUMBER	READ/WRITE	0~65535
40102	00 65	TOTAL NUMBER OF MEASURING POINTS	READ/WRITE	1~20
40103	00 66	DEVICE ADDRESS	READ/WRITE	1~249
40104	00 67	BAUD RATE	READ/WRITE	0~6
40105	00 68	COMMUNICATION MODE	READ/WRITE	1~4
40106	00 69	THE TYPE OF PROTOCOL	READ/WRITE	1~10

In the case of broken wires, wire the wires as shown in the figure. If the product itself has no leads, the core color is for reference.

How to use?

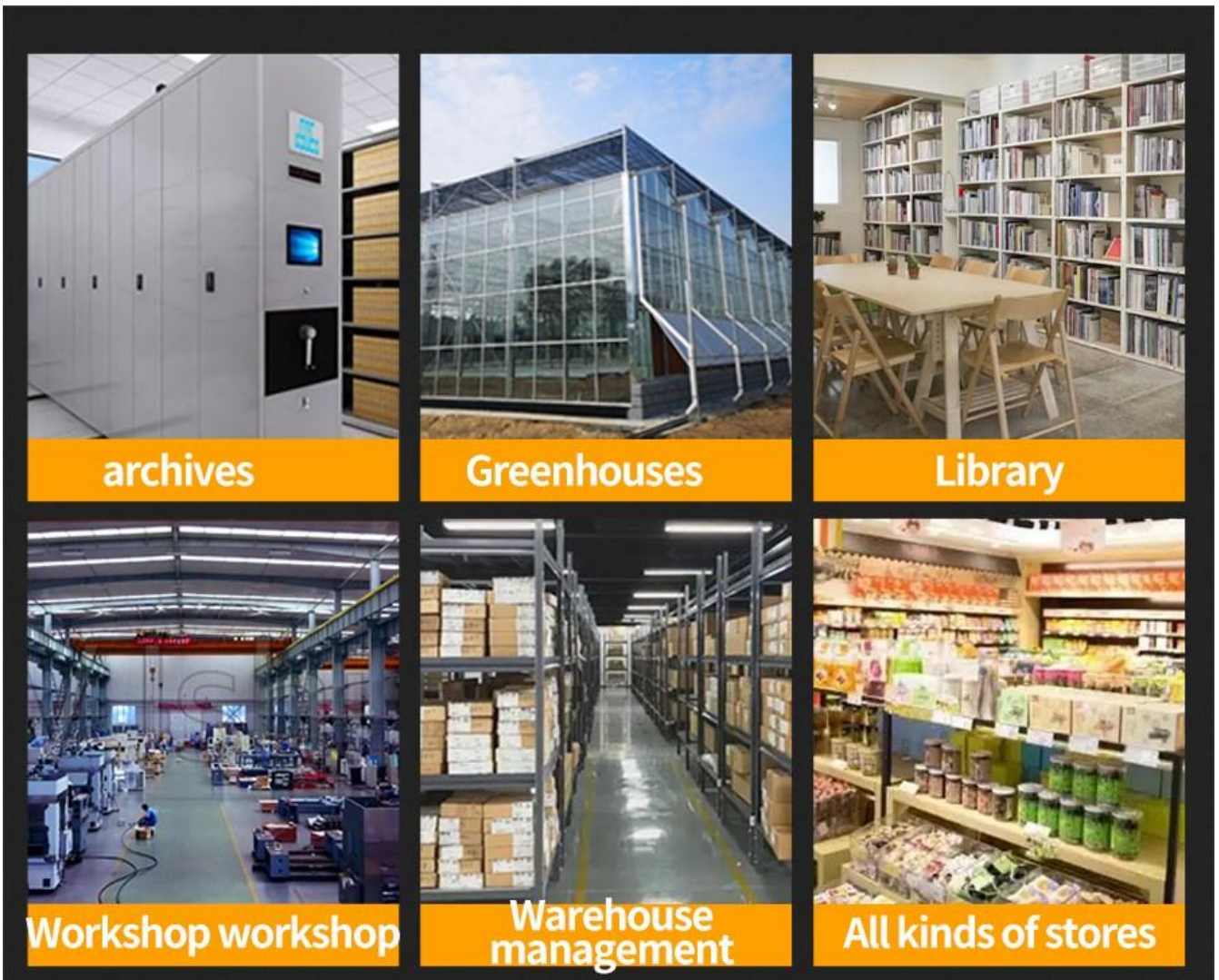

Application solution

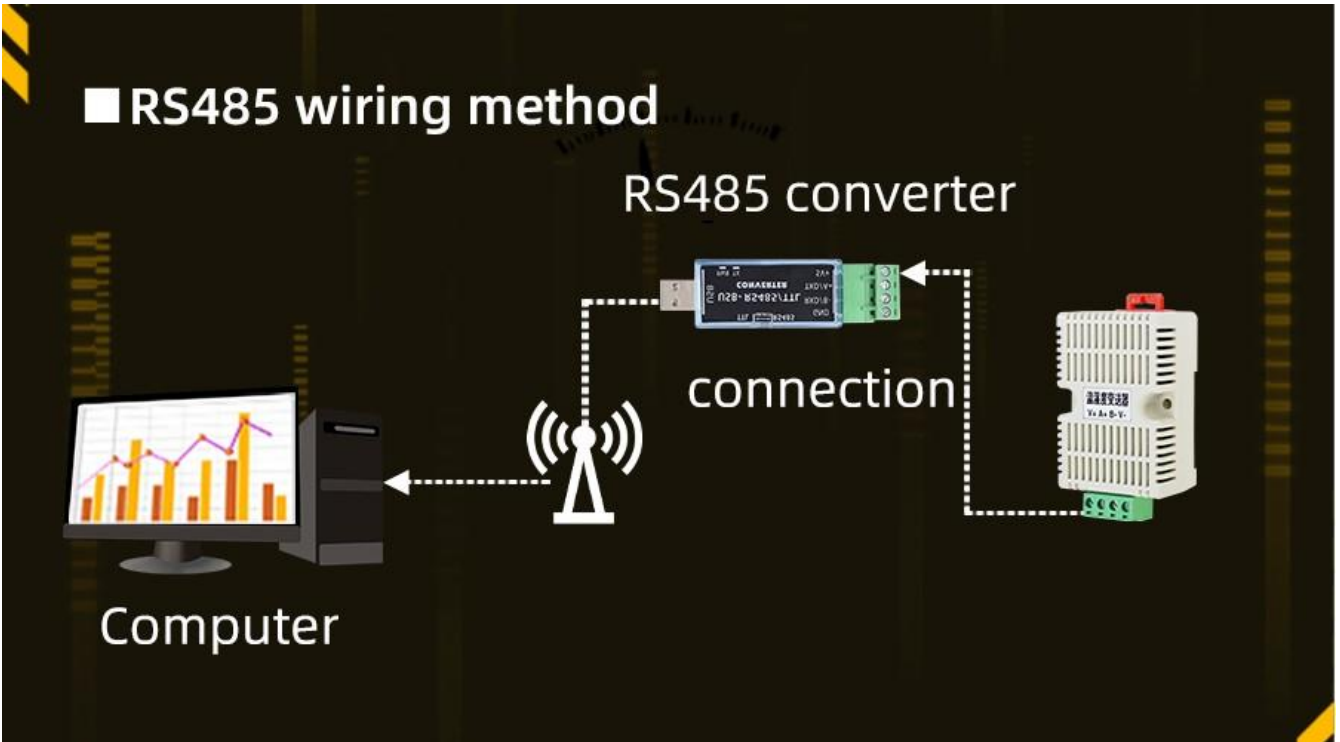

Product List



Temperature and humidity sensor



Reminder card



Certificate

Disclaimer

This document provides all information about the product, does not grant any license to intellectual property, does not express or imply, and prohibits any other means of granting any intellectual property rights, such as the statement of sales terms and conditions of this product, other issues. No liability is assumed. Furthermore, our company makes no warranties, express or implied, regarding the sale and use of this product, including the suitability for the specific use of the product, the marketability or the infringement liability for any patent, copyright or other intellectual property rights, etc. Product specifications and product descriptions may be modified at any time without notice.

Contact Us

Company: Shanghai Sonbest Industrial Co., Ltd KLHA Brand Division
 Address: Building 8, No.215 North east road, Baoshan District, Shanghai, China
 Web: <http://www.klha.com>
 Web: <http://www.klha.com>
 SKYPE: soobuu
 Email: sale@sonbest.com
 Tel: 86-021-51083595 / 66862055 / 66862075 / 66861077