

KM37M90

4-20MA High temperature hot air duct wind speed sensor

User Manual

File Version: V21.2.15

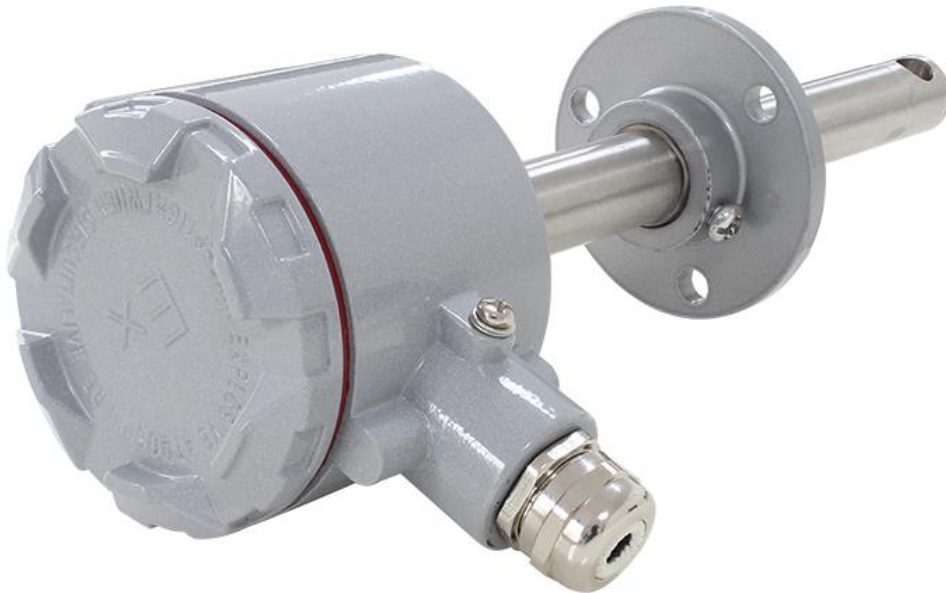

KM37M90 using the standard DC4-20mA current output signal,easy access to PLC , DCS and other instruments or systems for monitoring wind speed state quantities.The internal use of high -precision sensing core and related devices to ensure high reliability and excellent long-term stability,can be customized RS232,RS485,CAN,4-20mA,DC0~5V\10V,ZIGBEE,Lora,WIFI,GPRS and other output methods.

Technical Parameters

Technical parameter	Parameter value
---------------------	-----------------

Wind speed range	0~30m/s
Wind speed accuracy	± 3%
Induction principle	Thermal film induction
Communication Interface	DC4~20mA
Power	DC12~24V 1A
Running temperature	-40~80°C
Working humidity	5%RH~90%RH

Product Size

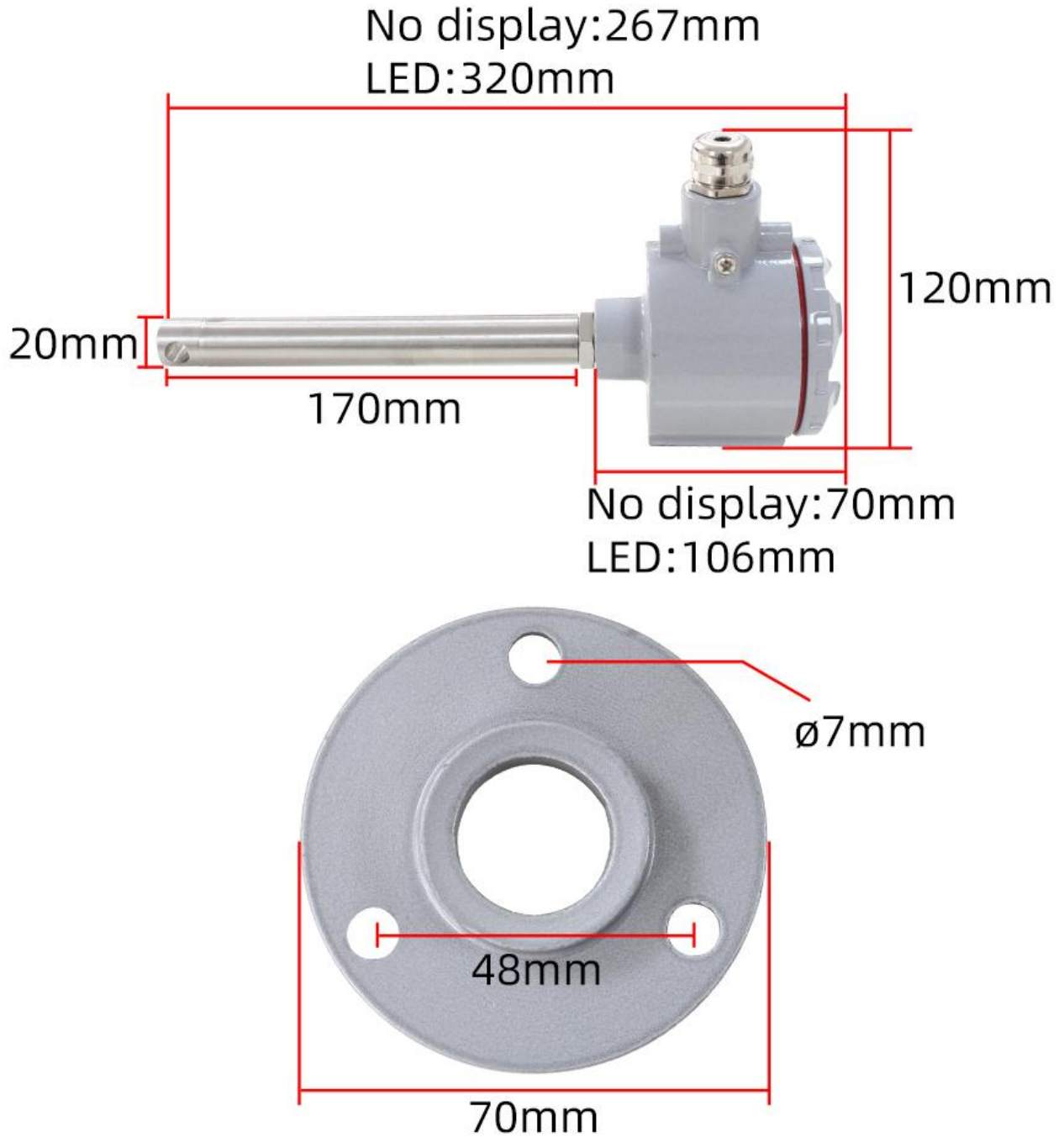

How to wiring?



ORIENTED DESIGN

Let the wind flow smoothly
More accurate measurement data

IP67 PROTECTIVE SHELL

Protect the internal circuit board
Heat-resistant, cold-resistant
and dust-proof









FLANGE MOUNTING PLATE

Sensor installation is more convenient

RS485 Wiring

	RD	PWR+
	GN	PWR-
	YE	RS485 A+
	BU	RS485 B-

※Note: When wiring, connect the positive and negative poles of the power supply first, and then connect the signal line

Application solution

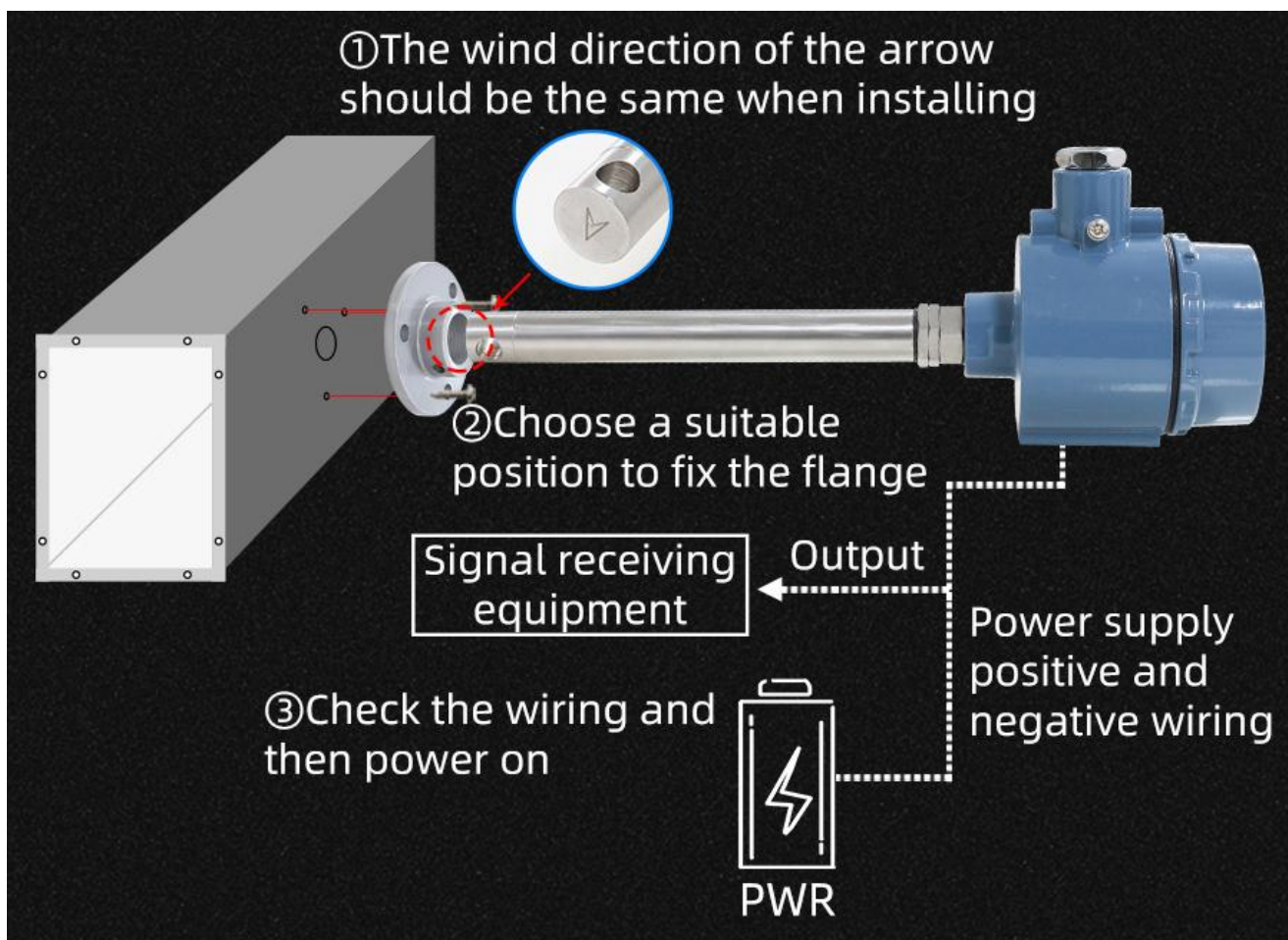

How to use?



Disclaimer

This document provides all information about the product, does not grant any license to intellectual property, does not express or imply, and prohibits any other means of granting any intellectual property

rights, such as the statement of sales terms and conditions of this product, other issues. No liability is assumed. Furthermore, our company makes no warranties, express or implied, regarding the sale and use of this product, including the suitability for the specific use of the product, the marketability or the infringement liability for any patent, copyright or other intellectual property rights, etc. Product specifications and product descriptions may be modified at any time without notice.

Contact Us

Company: Shanghai Sonbest Industrial Co., Ltd KLHA Brand Division

Address: Building 8, No. 215 North east road, Baoshan District, Shanghai, China

Web: <http://www.klha.com>

Web: <http://www.klha.com>

SKYPE: soobuu

Email: sale@sonbest.com

Tel: 86-021-51083595 / 66862055 / 66862075 / 66861077