

SM2130V-CO

Carbon monoxide sensor

User Manual

File Version: V23.8.8



SM2130V-CO using the standard ,easy access to PLC , DCS and other instruments or systems for

monitoring carbon monoxide state quantities. The internal use of high-precision sensing core and related devices to ensure high reliability and excellent long-term stability, can be customized RS232, RS485, CAN, 4-20mA, DC0~5V\10V, ZIGBEE, Lora, WIFI, GPRS and other output methods.

Technical Parameters

Technical parameter	Parameter value
Brand	SONBEST
CO range	0~100ppm
CO accuracy	±10ppm
Power	DC9~24V 1A
Running temperature	-30~85℃
Working humidity	5%RH~90%RH

Product Size

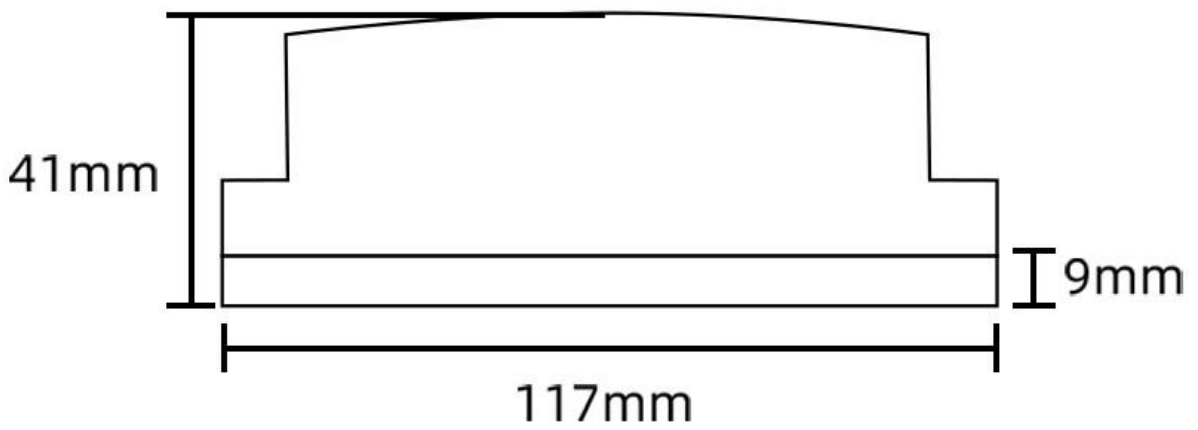
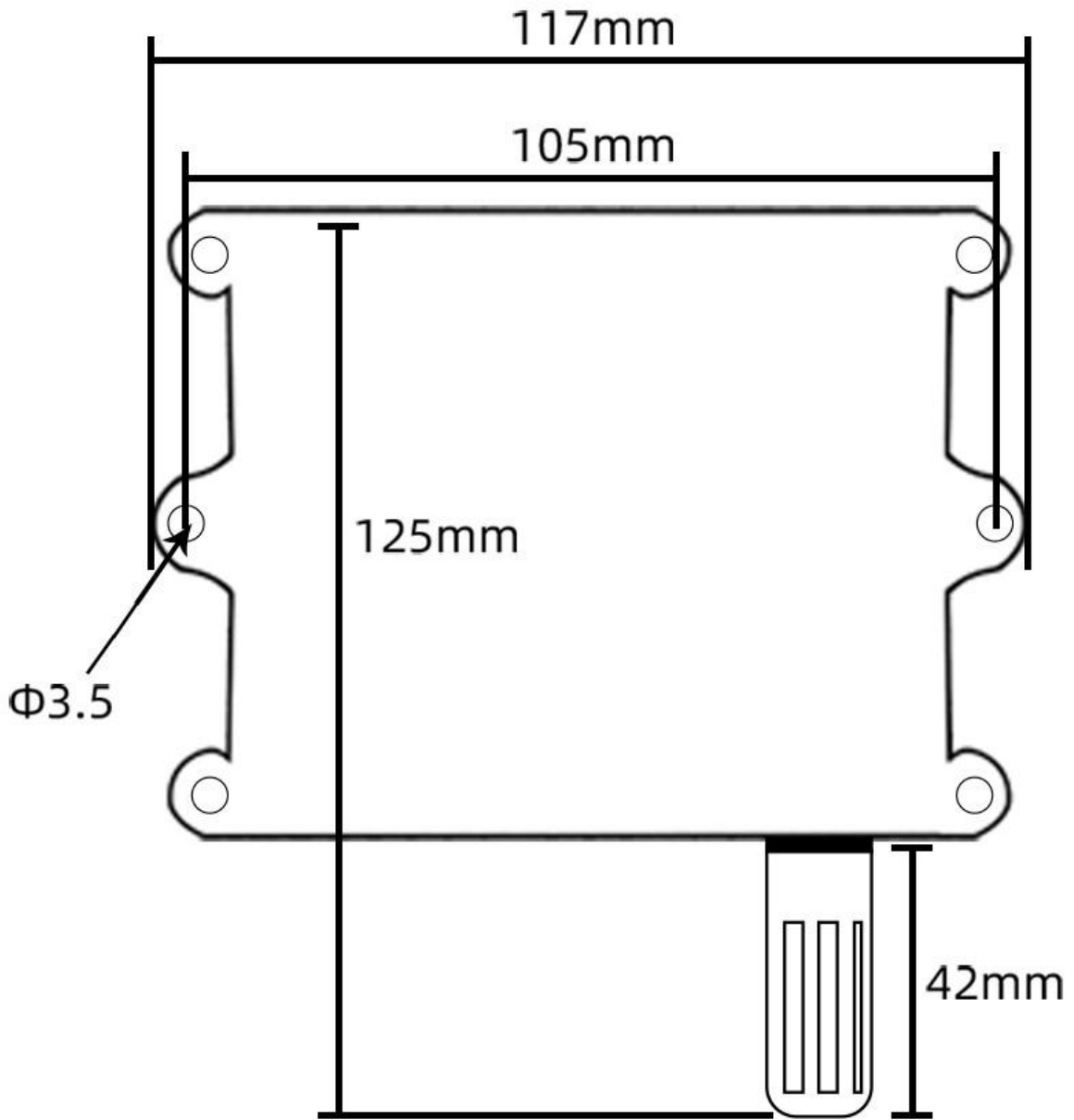

In the case of broken wires, wire the wires as shown in the figure. If the product itself has no leads, the core color is for reference.

How to use?

Carbon monoxide sensors can be widely used in animal breeding, file management, food storage, greenhouses, pharmaceutical storage, tobacco industry, industrial control industry and other indoor and outdoor temperature and humidity measurement fields



Application solution

■ RS485 Wiring

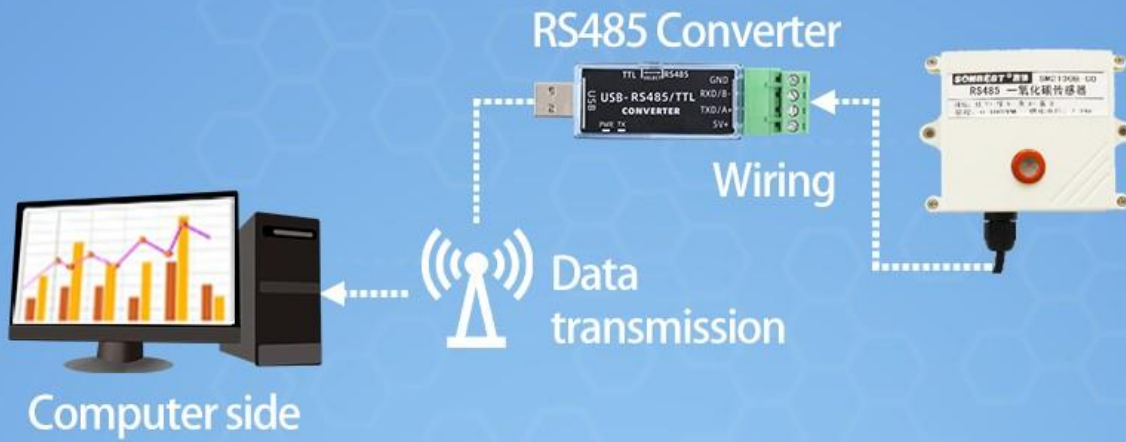

■ Current & voltage wiring method

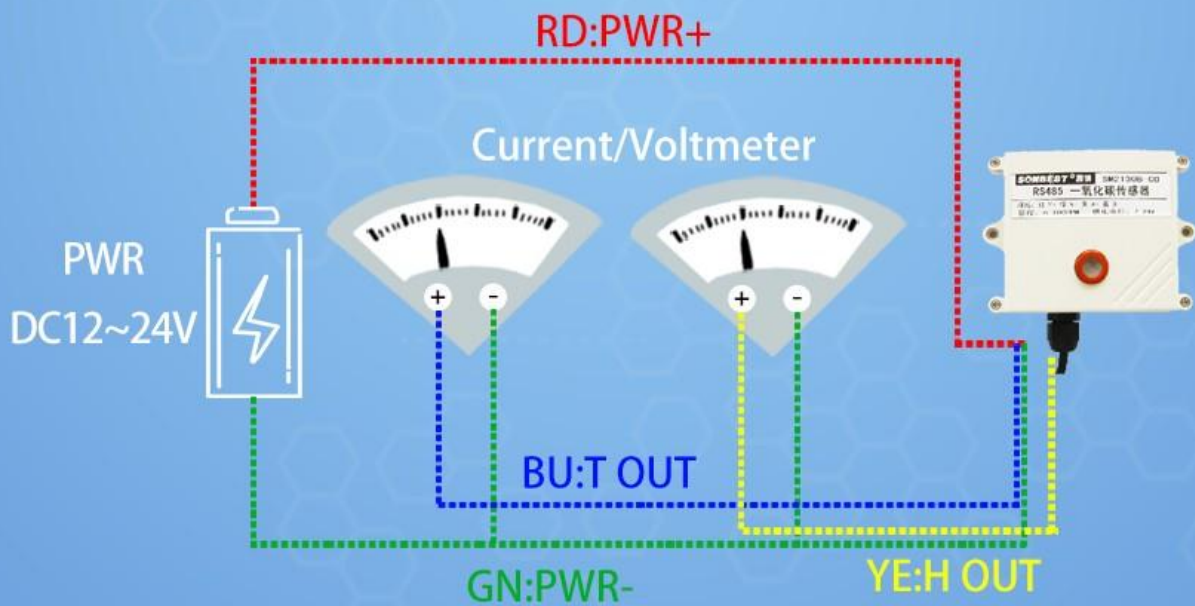

Product List



SM2130V-CO
carbon monoxide sensor
(excluding converter and power supply)



Reminder card



Certificate

Disclaimer

This document provides all information about the product, does not grant any license to intellectual property, does not express or imply, and prohibits any other means of granting any intellectual property rights, such as the statement of sales terms and conditions of this product, other issues. No liability is assumed. Furthermore, our company makes no warranties, express or implied, regarding the sale and use of this product, including the suitability for the specific use of the product, the marketability or the infringement liability for any patent, copyright or other intellectual property rights, etc. Product specifications and product descriptions may be modified at any time without notice.

Contact Us

Company: Shanghai Sonbest Industrial Co., Ltd

Address: Building 8, No. 215 North east road, Baoshan District, Shanghai, China

Web: <http://www.sonbest.com>

Web: <http://www.sonbus.com>

SKYPE: soobuu

Email: sale@sonbest.com

Tel: 86-021-51083595 / 66862055 / 66862075 / 66861077

