

SM3370M

4-20mA current type imported infrared carbon dioxide sensor

User Manual

File Version: V23.8.1



SM3370M using the standard DC4-20mA current output signal,easy access to PLC , DCS and other instruments or systems for monitoring carbon dioxide state quantities.The internal use of high-precision sensing core and related devices to ensure high reliability and excellent long-term stability,can be customized RS232,RS485,CAN,4-20mA,DC0~5V\10V,ZIGBEE,Lora,WIFI,GPRS and other output methods.

Technical Parameters

| Technical parameter | Parameter value |
|-------------------------|-----------------|
| Brand | SONBEST |
| CO2 range | 0~5000ppm |
| CO2 accuracy | ±100ppm |
| Communication Interface | DC4~20mA |
| Power | DC12~24V 1A |
| Running temperature | -30~85℃ |
| Working humidity | 5%RH~90%RH |

Product Size



Wiring instructions

In the case of broken wires, wire the wires as shown in the figure. If the product itself has no leads, the core color is for reference.

How to use?

Infrared CO2 sensors can be used in intelligent industries, Environmental monitoring, agriculture, meteorology, homes, construction sites and other places that need converters



Application solution

■ RS485 connection mode

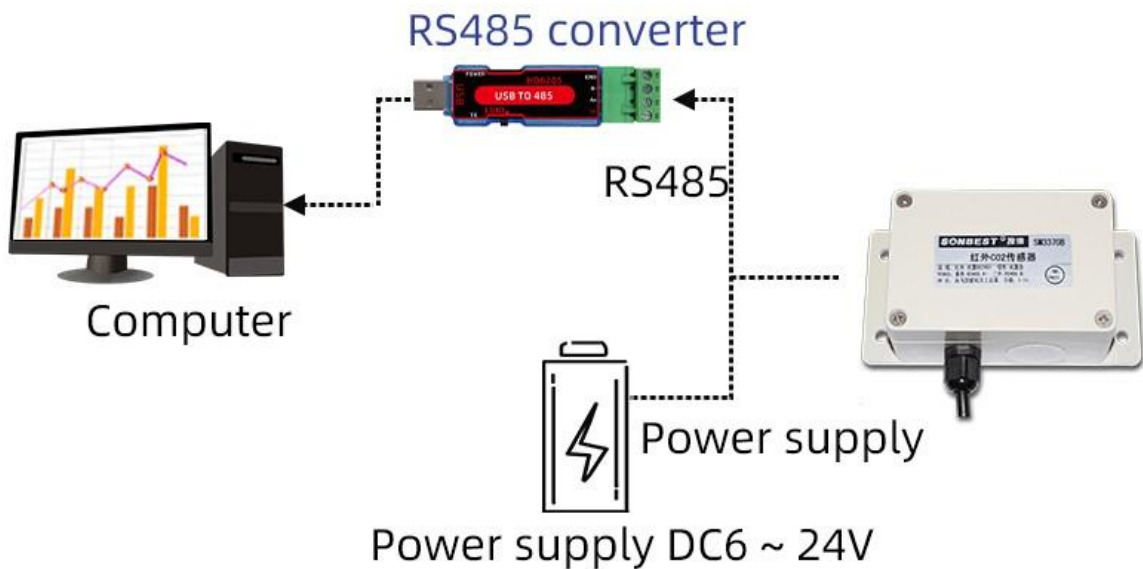

■ Current connection mode

Red: power positive

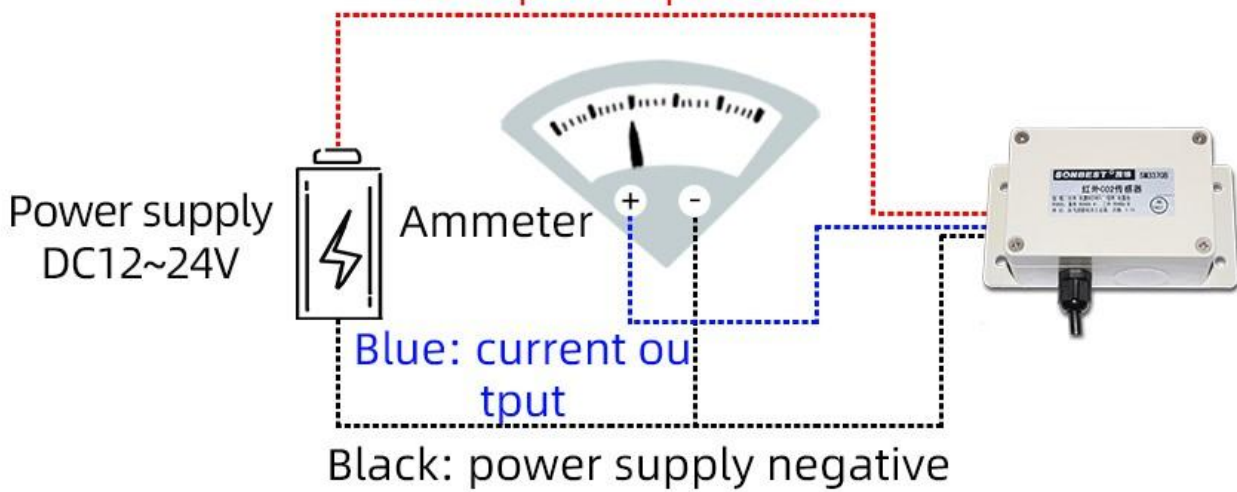

■ Voltage Connection mode

Red: power positive

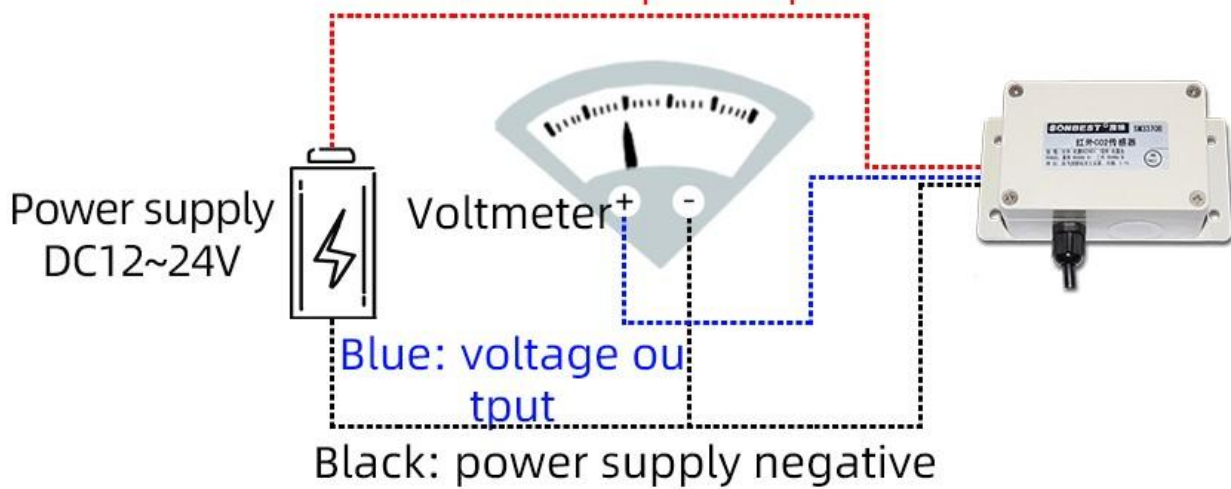

Product List



Infrared CO2 sensor



Warm Reminder card



Certificate

Disclaimer

This document provides all information about the product, does not grant any license to intellectual property, does not express or imply, and prohibits any other means of granting any intellectual property rights, such as the statement of sales terms and conditions of this product, other issues. No liability is assumed. Furthermore, our company makes no warranties, express or implied, regarding the sale and use of this product, including the suitability for the specific use of the product, the marketability or the infringement liability for any patent, copyright or other intellectual property rights, etc. Product specifications and product descriptions may be modified at any time without notice.

Contact Us

Company: Shanghai Sonbest Industrial Co., Ltd

Address: Building 8, No.215 North east road, Baoshan District, Shanghai, China

Web: <http://www.sonbest.com>

Web: <http://www.sonbus.com>

SKYPE: soobuu

Email: sale@sonbest.com

Tel: 86-021-51083595 / 66862055 / 66862075 / 66861077