

SZ5110D

Wireless LCD networking temperature and humidity sensor

User Manual

File Version: V23.8.21



SZ5110D using the standard ZIGBEE Wireless Communication Interface,easy access to PLC , DCS and other instruments or systems for monitoring temperature,humidity state quantities.The internal use of high-precision sensing core and related devices to ensure high reliability and excellent long-term stability,can be customized RS232,RS485,CAN,4-20mA,DC0~5V\10V,ZIGBEE,Lora,WIFI,GPRS and other output methods.

Technical Parameters

Technical parameter	Parameter value
Brand	SONBEST
Temperature measuring range	-30℃~80℃
Temperature measuring accuracy	±0.5℃ @25℃
Humidity measuring range	0~100%RH
Humidity accuracy	±3%RH @25℃
Communication Interface	ZIGBEE
Radio frequency	2.4G ISM
Network Type	Star network
Network capacity	65535
Power	DC9~24V 1A
Display	LCD
Running temperature	-30~85℃
Working humidity	5%RH~90%RH

Product Size

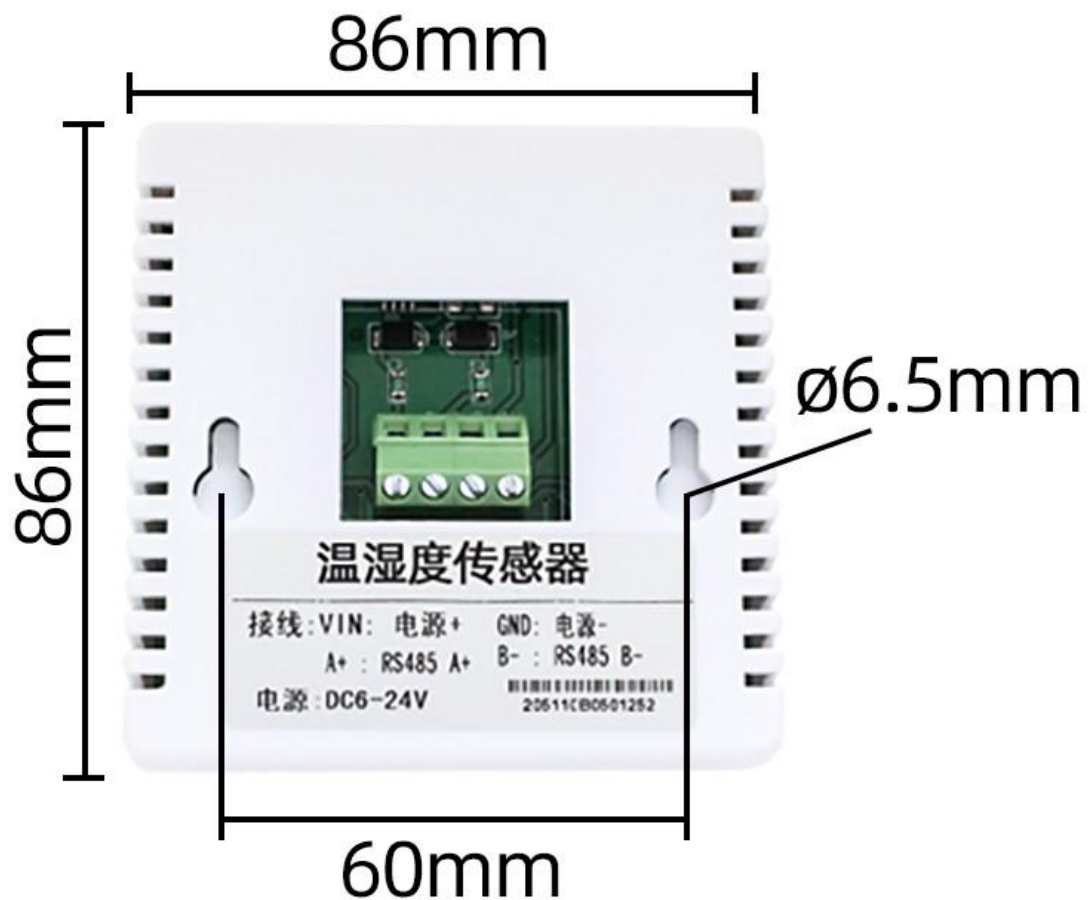



Click SET to enter the baud rate and change the address settings:

F 1 and f 2 change the baud rate size by default to 9600, with 9.6 representing 9600

There are five baud rates available:

2400、4800、9600、19200、38400

F 3 and F 4 change address

Press the second SET to enter the upper and lower temperature adjustment:

F 1 and f 2 change the upper temperature limit

F 3 and F 4 change the lower temperature limit

Press the third SET to enter the upper and lower limits of humidity adjustment:

F 1 and f 2 change the humidity ceiling

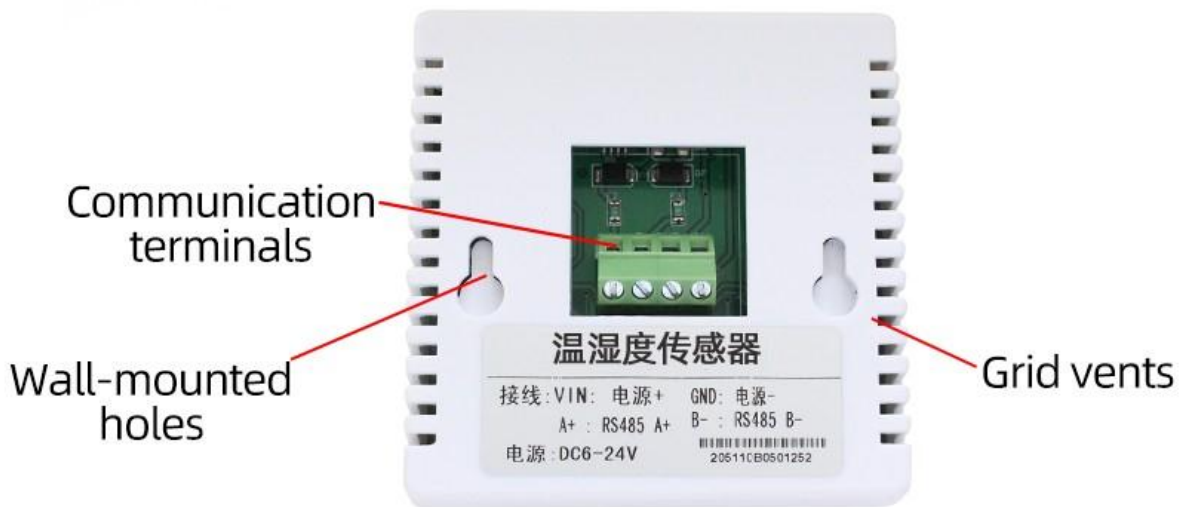

Wiring mode



Connection Mode

-
- A+ RS485 A+
- B- RS485 B-
- GND Power Supply Negative
- VIN Power Supply Positive Pole
-

Wiring instructions

In the case of broken wires, wire the wires as shown in the figure. If the product itself has no leads, the core color is for reference.

How to use?

Wireless LCD networking temperature and humidity sensor is mainly used in food storage and transportation, museum cultural relics, archive management, building materials experiment, agriculture, forestry and animal husbandry applications, building acceptance, important medical and health places, pipeline maintenance, etc



Application solution

■ **How to use SZ5110D**

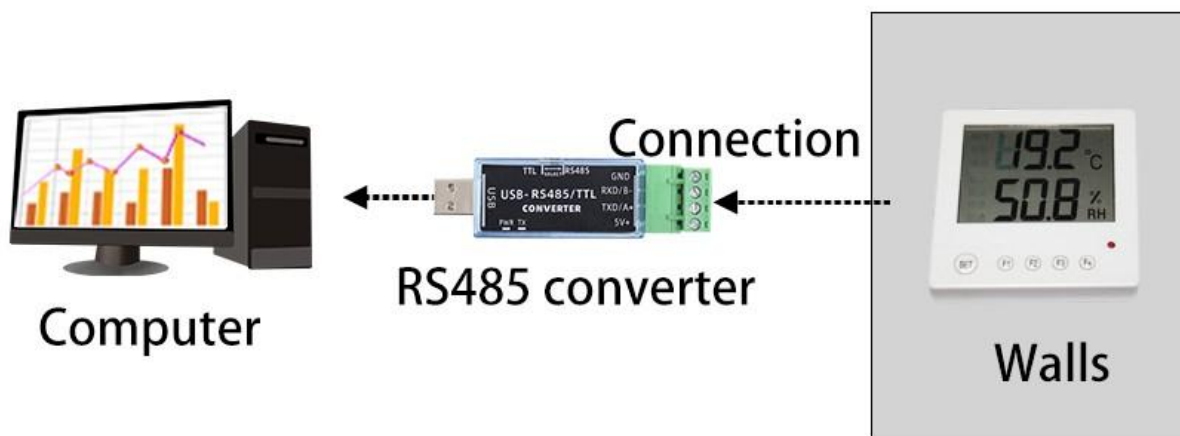

Product List



SZ5110D
(without power supply)



Reminder card



Certificate

Disclaimer

This document provides all information about the product, does not grant any license to intellectual property, does not express or imply, and prohibits any other means of granting any intellectual property rights, such as the statement of sales terms and conditions of this product, other issues. No liability is assumed. Furthermore, our company makes no warranties, express or implied, regarding the sale and use of this product, including the suitability for the specific use of the product, the marketability or the infringement liability for any patent, copyright or other intellectual property rights, etc. Product specifications and product descriptions may be modified at any time without notice.

Contact Us

Company: Shanghai Sonbest Industrial Co., Ltd

Address: Building 8, No. 215 North east road, Baoshan District, Shanghai, China

Web: <http://www.sonbest.com>

Web: <http://www.sonbus.com>

SKYPE: soobuu

Email: sale@sonbest.com

Tel: 86-021-51083595 / 66862055 / 66862075 / 66861077