

SZ6070D

ZIGBEE wireless industrial infrared CO2 sensor

User Manual

File Version: V23.8.17



SZ6070D using the standard ZIGBEE Wireless Communication Interface, easy access to PLC, DCS and other instruments or systems for monitoring carbon dioxide state quantities. The internal use of high-precision sensing core and related devices to ensure high reliability and excellent long-term stability, can be customized RS232, RS485, CAN, 4-20mA, DC0~5V/10V, ZIGBEE, Lora, WIFI, GPRS and other output methods.

Technical Parameters

Technical parameter	Parameter value
Brand	SONBEST
CO2 range	0~5000ppm
CO2 accuracy	±100ppm
Communication Interface	ZIGBEE
Radio frequency	2.4G ISM
Network Type	Star network
Network capacity	65535
Power	DC9~24V 1A
Display	LCD
Running temperature	-30~85℃
Working humidity	5%RH~90%RH





Product Size



Wiring mode



RS485 Wiring

	V+	PWR+
	V-	PWR-
	A+	RS485+
	B-	RS485-

※Note: Connect the positive and negative poles of the power supply first, and then connect the signal wire

Wiring instructions

In the case of broken wires, wire the wires as shown in the figure. If the product itself has no leads, the core color is for reference.

How to use?

ZIGBEE wireless industrial infrared carbon dioxide sensor can be widely used in air quality detection, ambient climate carbon dioxide concentration, industrial plant indoor air quality, greenhouse air quality and other indoor and outdoor environmental measurement



Application solution

The data cable wiring is simple, the response speed is fast, and the data transmission efficiency is high. Long-term stability and reliability, excellent performance

■ RS485 wiring method

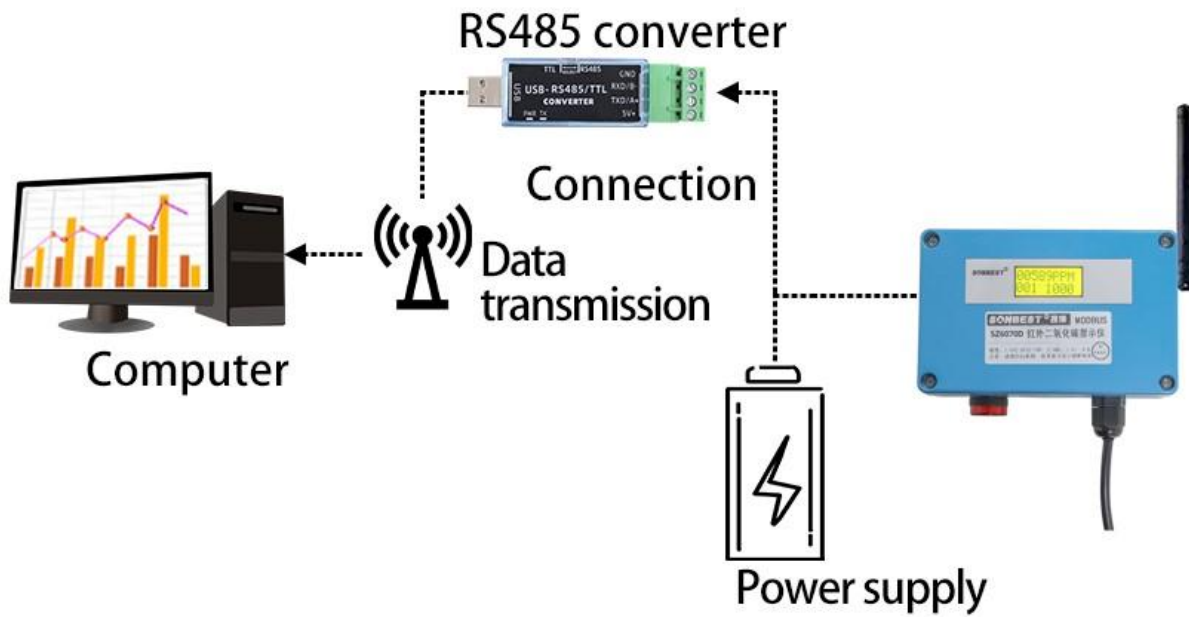

Product List



**ZIGBEE wireless industrial
infrared CO2 sensor**



Reminder card



Certificate

Disclaimer

This document provides all information about the product, does not grant any license to intellectual property, does not express or imply, and prohibits any other means of granting any intellectual property rights, such as the statement of sales terms and conditions of this product, other issues. No liability is assumed. Furthermore, our company makes no warranties, express or implied, regarding the sale and use of this product, including the suitability for the specific use of the product, the marketability or the infringement liability for any patent, copyright or other intellectual property rights, etc. Product specifications and product descriptions may be modified at any time without notice.

Contact Us

Company: Shanghai Sonbest Industrial Co., Ltd

Address: Building 8, No.215 North east road, Baoshan District, Shanghai, China

Web: <http://www.sonbest.com>

Web: <http://www.sonbus.com>

SKYPE: soobuu

Email: sale@sonbest.com

Tel: 86-021-51083595 / 66862055 / 66862075 / 66861077