

YM3716

Long-probe High-precision Duct Temperature and Humidity Sensor User Manual

File Version: V26.5.28



YM3716 using the standard ,easy access to PLC , DCS and other instruments or systems for monitoring temperature,humidity state quantities.The internal use of high-precision sensing core and related devices to ensure high reliability and excellent long-term stability,can be customized

RS232,RS485,CAN,4-20mA,DC0~5V\10V,ZIGBEE,Lora,WIFI,GPRS and other output methods.

Technical Parameters

Technical parameter	Parameter value
Temperature measuring range	-30℃~80℃
Temperature measuring accuracy	±0.5℃ @25℃
Humidity measuring range	0~100%RH
Humidity accuracy	±3%RH @25℃
Interface	RS485/4-20mA/DC0-5V/DC0-10V
Power	DC12~24V 1A
Running temperature	-30~80℃
Working humidity	5%RH~90%RH

Product Selection

Product Design RS485,4-20mA,DC0-5V,DC0-10V Multiple output methods, the products are divided into the following models depending on the output method.

Product model	output method
YM3716B	RS485 总线
YM3716M	4-20mA
YM3716V5	DC0-5V
YM3716V10	DC0-10V

Product Size



software to test

Read the data function code 03

All operation commands are hexadecimal data, and the default communication baud rate: 9600,8,N,1

Query frame (hexadecimal), send example: query 1# device 1 data,

The host computer sends the command: 01 03 00 00 00 02 c4 0b

CMD	ADD	MOD	SA	LEN	CAPTCHA
CMD	01	03	00 00	00 02	C4 0B

Response frame (hexadecimal): 01 03 02 02 18 B9 2E

CMD	ADD	MOD	LEN	DATA	CAPTCHA
CMD	01	03	02	00 79 00 7A	AA 09

In the response data in the above example, since the temperature and humidity are two measurement points, the data occupies a total of 4 bytes, for example, the data is 00 79 00 7A, where the first two bytes are temperature data and the last two bytes are humidity data. temperature, The magnification of the humidity is 100, which is the true value of the read data divided by 100.

For the temperature 00 79 (hexadecimal), converted to 10 decimal data is 121, then the true value is: $121/100 = 1.21$, that is, the temperature is 1.21 degrees.

When the value is negative, the data is uploaded in the form of a complement.

Positive or negative is usually determined by the method of judging whether the value is greater than 32768. When the received value is greater than 32768 is negative, and the previous value minus 65535 divided by 100 is the true value.

For example, the temperature received. If the degree data is 62999 (hexadecimal F617), then the true value = $(62999 - 65535)/100 = -25.36$.

For humidity 00 7A (hexadecimal), converted to 122 in decimal data, the true value is: $122/100 = 1.22$, i.e. the temperature is 1.21%RH.

Use of Software

STATUS QUANTITY DATA REGISTER

ADDR.	REG	TITLE	R/W	NOTE
40001	00 00	T REGISTERS	R	0~65535
40002	00 01	H REGISTERS	R	0~65535

PARAMETER REGISTERS

ADDR.	REG	TITLE	R/W	NOTE
40101	00 64	TYPE ID	R	0~59999
40102	00 65	POINTS	R	1~20
40103	00 66	ADDRESS	R/W	1~249
40104	00 67	BAUD RATE	R/W	0~6
40105	00 68	MODE	R/W	1. QUERY 2. UPLOAD
40106	00 69	PROTOCOL	R/W	1 MODBUS-RTU
40107	00 6A	INTERVAL	R/W	1~36000
40108	00 6B	VALUE	R/W	SOME PRODUCTS ARE AVAILABLE

In the case of broken wires, wire the wires as shown in the figure. If the product itself has no leads, the core color is for reference.

How to use software?

Read the data function code 03

All operation commands are hexadecimal data, and the default communication baud rate: 9600,8,N,1

Query frame (hexadecimal), send example: query 1# device 1 data,

The host computer sends the command: 01 03 00 00 00 02 c4 0b

CMD	ADD	MOD	SA	LEN	CAPTCHA
CMD	01	03	00 00	00 02	C4 0B

Response frame (hexadecimal): 01 03 02 02 18 B9 2E

CMD	ADD	MOD	LEN	DATA	CAPTCHA
CMD	01	03	02	00 79 00 7A	AA 09

In the response data in the above example, since the temperature and humidity are two measurement points, the data occupies a total of 4 bytes, for example, the data is 00 79 00 7A, where the first two bytes are temperature data and the last two bytes are humidity data. temperature, The magnification of the humidity is 100, which is the true value of the read data divided by 100.

For the temperature 00 79 (hexadecimal), converted to 10 decimal data is 121, then the true value is: $121/100 = 1.21$, that is, the temperature is 1.21 degrees.

When the value is negative, the data is uploaded in the form of a complement.

Positive or negative is usually determined by the method of judging whether the value is greater than 32768. When the received value is greater than 32768 is negative, and the previous value minus 65535 divided by 100 is the true value.

For example, the temperature received. If the degree data is 62999 (hexadecimal F617), then the true value = $(62999 - 65535)/100 = -25.36$.

For humidity 00 7A (hexadecimal), converted to 122 in decimal data, the true value is: $122/100 = 1.22$, i.e. the temperature is 1.21%RH.

Use of Software

STATUS QUANTITY DATA REGISTER

ADDR.	REG	TITLE	R/W	NOTE
40001	00 00	T REGISTERS	R	0~65535
40002	00 01	H REGISTERS	R	0~65535

PARAMETER REGISTERS

ADDR.	REG	TITLE	R/W	NOTE
40101	00 64	TYPE ID	R	0~59999
40102	00 65	POINTS	R	1~20
40103	00 66	ADDRESS	R/W	1~249
40104	00 67	BAUD RATE	R/W	0~6
40105	00 68	MODE	R/W	1. QUERY 2. UPLOAD
40106	00 69	PROTOCOL	R/W	1 MODBUS-RTU
40107	00 6A	INTERVAL	R/W	1~36000
40108	00 6B	VALUE	R/W	SOME PRODUCTS ARE AVAILABLE

How to use?

Temperature and humidity sensors can be widely used in granary warehouses, heat source heat pumps, computer room workshops, libraries, museums, greenhouses, archives and other indoor measurement fields



Application solution

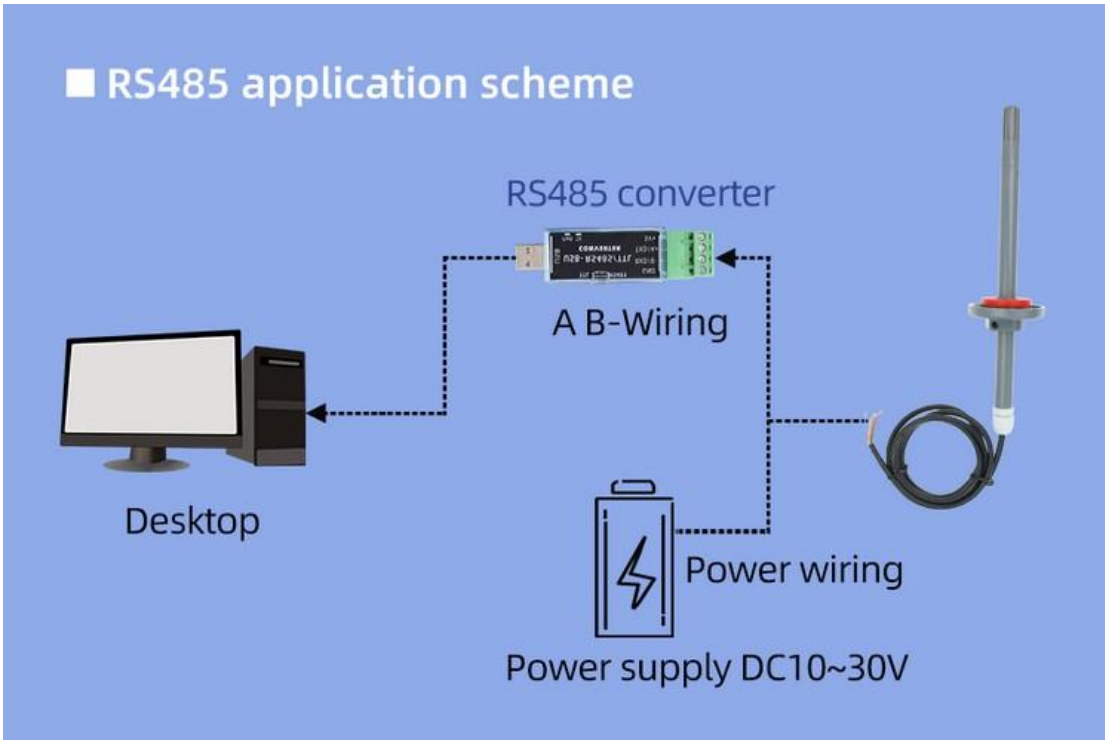

Product List



Certificate

The number of T and H sensors in the response data of the above example is 1
(The actual delivery is subject to the user's selection)

Communication Protocol

The product uses the RS485 MODBUS-RTU standard protocol format, and all operation or reply commands are in hexadecimal data. When the device leaves the factory, the default device address is 1, and the default baud rate is: for modules and non-recording instruments: 9600, 8, n, 1 (for the recorder series products, the default is: 115200, 8, n, 1).

1. Read data (Function code 0x03)

The inquiry frame (in hexadecimal). Example of sending: To query 1 piece of data of device No. 1, the host computer sends the command: 01 03 00 00 00 02 C4 0B .

Address	Function code	Starting address	Data length	Checksum
01	03	00 00	00 02	C4 0B

For a correct inquiry frame, the device will respond with data: 01 03 04 02 19 00 00 2A 4C , and the response format is:

Address	Function code	Length	Data 1	Data 2	Checksum
01	03	04	02 18	02 19	2A 4C

Data description: The data in the command is in hexadecimal. Taking Data 1 as an example, 02 18 converted to decimal value is 536. Assuming the data magnification factor is 100, then the true value is $536/100 = 5.36$, and the others can be deduced by analogy.

2. Common Data Address Table

Configuration Address	Register Address	Register Description	Data Type	Value Range
40001	00 00	temperature	Read Only	0~65535
40002	00 01	humidity	Read Only	0~65535
40101	00 64	Model Code	Read-only	0~59999
40102	00 65	Total Number of Measuring Points	Read-only	1~1600
40103	00 66	Device Address	Read/Write	1~249
40104	00 67	Baud Rate	Read/Write	0~6
40105	00 68	Communication Mode	Read/Write	1 Query
40106	00 69	Protocol Type	Read/Write	1 MODBUS-RTU

3. Read and modify the device address

(1) Read or query the device address

If you don't know the current device address and there is only one device on the bus, you can query the device address through the command FA 03 00 66 00 01 71 9E .

Device address	Function code	Starting address	Data length	Checksum
FA	03	00 66	00 01	71 9E

FA, which is 250, is the universal address. When you don't know the address, you can use 250 to obtain the real device address. 00 66 is the register of the device address.

For a correct query command, the device will respond. For example, the response data is: 01 03 02 00 01 79 84. The format analysis is shown in the following table:

Device address	Function code	Starting address	Address ID	Checksum
01	03	02	00 01	79 84

In the response data, the first byte 01 represents the real address of the current device.

(2) Change the device address

For example, if the current device address is 1 and you want to change it to 02, the command is: 01 06 00 66 00 02 E8 14 .

Device address	Function code	Register address	Target address	Checksum
01	06	00 66	00 02	E8 14

After the change is successful, the device will return the information: 02 06 00 66 00 02 E8 27. The format analysis is shown in the following table:

Device address	Function code	Register address	Target address	Checksum
02	06	00 66	00 02	E8 27

In the response data, after the modification is successful, the first byte is the new device address. Generally, after the device address is changed, it takes effect immediately. At this time, users need to modify the query commands in their own software accordingly.

4. Read and modify the baud rate

(1) Read the baud rate

The default factory baud rate of the device is 9600. If you need to change it, you can perform the change operation according to the following table and the corresponding communication protocol. For example, to read the baud rate ID of the current device, the command is: 01 03 00 67 00 01 35 D5 . The format analysis is as follows.

Device address	Function code	Starting address	Data length	Checksum
01	03	00 67	00 01	35 D5

Read the baud rate code of the current device. Baud rate codes: 1 for 2400; 2 for 4800; 3 for 9600; 4 for 19200; 5 for 38400; 6 for 115200.

For a correct query command, the device will respond. For example, the response data is: 01 03 02 00 03 F8 45. The format analysis is shown in the following table:

Device address	Function code	Data length	Baud rate code	Checksum
01	03	02	00 03	F8 45

According to the baud rate code, 03 represents 9600, which means the current baud rate of the device is 9600.

(2) Change the baud rate

For example, to change the baud rate from 9600 to 38400, that is, change the code from 3 to 5, the command is: 01 06 00 67 00 05 F8 16 .

Device address	Function code	Register address	Target baud rate	Checksum
01	06	00 67	00 05	F8 16

Change the baud rate from 9600 to 38400, that is, change the code from 3 to 5. The new baud rate will take effect immediately. At this time, the device will stop responding, and the query command for the device's baud rate needs to be modified accordingly.

5. Read and modify the correction value (valid for some products)

(1) Read the correction value

When there is an error between the data and the reference standard, we can reduce the display error by adjusting the "correction value". The adjustable range of the correction difference is plus or minus 1000, that is, the value range is 0 - 1000 or 64535 - 65535. For example, when the displayed value is 100 less than the actual value, we can correct it by adding 100. The command is: 01 03 00 6B 00 01 F5 D6 . In the command, 100 is the hexadecimal value 0x64. If you need to decrease the value, you can set a negative value. For example, - 100 corresponds to the hexadecimal value FF 9C. The calculation method is 100 - 65535 = 65435, and then convert it to hexadecimal, which is 0x FF 9C. The device correction value starts from 00 6B. We take the first parameter as an example for illustration. When there are multiple parameters, the methods for reading and modifying the correction value are the same.

Device address	Function code	Starting address	Data length	Checksum
----------------	---------------	------------------	-------------	----------

01	03	00 6B	00 01	F5 D6
----	----	-------	-------	-------

For a correct query command, the device will respond. For example, the response data is: 01 03 02 00 64 B9 AF. The format analysis is shown in the following table:

Device address	Function code	Data length	Correction value	Checksum
01	03	02	00 64	B9 AF

In the response data, the first byte 01 represents the real address of the current device, and 00 6B is the register for the correction value of the first state variable. If the device has multiple parameters, the operation methods for other parameters are the same. Generally, temperature and humidity sensors have this parameter, while light sensors usually do not.

(2) Change the correction value

For example, if the current state variable value is too small and we want to increase its real - value by 1, the command to correct the current value by adding 100 is: 01 06 00 6B 00 64 F9 FD .

Device address	Function code	Register address	Target address	Checksum
01	06	00 6B	00 64	F9 FD

After the operation is successful, the device will return the information: 01 06 00 6B 00 64 F9 FD. After the change is successful, the parameter takes effect immediately.

1. temperature and current computing relationship

For example, the range is 0~50℃, the analog output is 4~20mA current signal, temperature and current The calculation relationship is as shown in the formula: $C = (A2-A1) * (X-B1) / (B2-B1) + A1$, where A2 is temperature range upper limit, A1 is the lower limit of the range, B2 is current output range upper limit, B1 is the lower limit, X is the currently read temperature value, and C is the calculated current value. The list of commonly used values is as follows:

current(mA)	temperatureValue (℃)	Calculation Process
4	0.0	$(50-0)*(4-4)÷(20-4)+0$
5	3.1	$(50-0)*(5-4)÷(20-4)+0$
6	6.3	$(50-0)*(6-4)÷(20-4)+0$
7	9.4	$(50-0)*(7-4)÷(20-4)+0$
8	12.5	$(50-0)*(8-4)÷(20-4)+0$
9	15.6	$(50-0)*(9-4)÷(20-4)+0$
10	18.8	$(50-0)*(10-4)÷(20-4)+0$
11	21.9	$(50-0)*(11-4)÷(20-4)+0$
12	25.0	$(50-0)*(12-4)÷(20-4)+0$
13	28.1	$(50-0)*(13-4)÷(20-4)+0$
14	31.3	$(50-0)*(14-4)÷(20-4)+0$
15	34.4	$(50-0)*(15-4)÷(20-4)+0$
16	37.5	$(50-0)*(16-4)÷(20-4)+0$
17	40.6	$(50-0)*(17-4)÷(20-4)+0$
18	43.8	$(50-0)*(18-4)÷(20-4)+0$
19	46.9	$(50-0)*(19-4)÷(20-4)+0$
20	50.0	$(50-0)*(20-4)÷(20-4)+0$

As shown in the above formula, when measuring 8mA, current current is 16.5℃。

2. humidity and current computing relationship

For example, the range is 0~100%RH, the analog output is 4~20mA current signal, humidity and current The calculation relationship is as shown in the formula: $C = (A2 - A1) * (X - B1) / (B2 - B1) + A1$, where A2 is humidity range upper limit, A1 is the lower limit of the range, B2 is current output range upper limit, B1 is the lower limit, X is the currently read humidity value, and C is the calculated current value. The list of commonly used values is as follows:

current(mA)	humidityValue (%RH)	Calculation Process
4	0.0	$(100-0)*(4-4)\div(20-4)+0$
5	6.3	$(100-0)*(5-4)\div(20-4)+0$
6	12.5	$(100-0)*(6-4)\div(20-4)+0$
7	18.8	$(100-0)*(7-4)\div(20-4)+0$
8	25.0	$(100-0)*(8-4)\div(20-4)+0$
9	31.3	$(100-0)*(9-4)\div(20-4)+0$
10	37.5	$(100-0)*(10-4)\div(20-4)+0$
11	43.8	$(100-0)*(11-4)\div(20-4)+0$
12	50.0	$(100-0)*(12-4)\div(20-4)+0$
13	56.3	$(100-0)*(13-4)\div(20-4)+0$
14	62.5	$(100-0)*(14-4)\div(20-4)+0$
15	68.8	$(100-0)*(15-4)\div(20-4)+0$
16	75.0	$(100-0)*(16-4)\div(20-4)+0$
17	81.3	$(100-0)*(17-4)\div(20-4)+0$
18	87.5	$(100-0)*(18-4)\div(20-4)+0$
19	93.8	$(100-0)*(19-4)\div(20-4)+0$
20	100.0	$(100-0)*(20-4)\div(20-4)+0$

As shown in the above formula, when measuring 8mA, current current is 29%RH。

1. temperature and DC0-5Vvoltage computing relationship

For example, the range is 0~50℃, the analog output is 0~5V DC0-5Vvoltage signal, temperature and DC0-5Vvoltage The calculation relationship is as shown in the formula: $C = (A2 - A1) * (X - B1) / (B2 - B1) + A1$, where A2 is temperature range upper limit, A1 is the lower limit of the range, B2 is DC0-5Vvoltage output range upper limit, B1 is the lower limit, X is the currently read temperature value, and C is the calculated DC0-5Vvoltage value. The list of commonly used values is as follows:

DC0-5Vvoltage(V)	temperatureValue (℃)	Calculation Process
0	0.0	$(50-0)*(0-0)\div(5-0)+0$
1	10.0	$(50-0)*(1-0)\div(5-0)+0$
2	20.0	$(50-0)*(2-0)\div(5-0)+0$
3	30.0	$(50-0)*(3-0)\div(5-0)+0$
4	40.0	$(50-0)*(4-0)\div(5-0)+0$
5	50.0	$(50-0)*(5-0)\div(5-0)+0$

As shown in the above formula, when measuring 2.5V, current DC0-5Vvoltage is 25℃。

2. humidity and DC0-5Vvoltage computing relationship

For example, the range is 0~100%RH, the analog output is 0~5V DC0-5Vvoltage signal, humidity and DC0-5Vvoltage The calculation relationship is as shown in the formula: $C = (A2 - A1) * (X - B1) / (B2 - B1) + A1$, where A2 is humidity range upper limit, A1 is the lower limit of the range, B2 is DC0-5Vvoltage output range upper limit, B1 is the lower limit, X is the currently read humidity value, and C is the calculated

DC0-5Vvoltage value. The list of commonly used values is as follows:

DC0-5Vvoltage(V)	humidityValue (%RH)	Calculation Process
0	0.0	$(100-0)*(0-0)\div(5-0)+0$
1	20.0	$(100-0)*(1-0)\div(5-0)+0$
2	40.0	$(100-0)*(2-0)\div(5-0)+0$
3	60.0	$(100-0)*(3-0)\div(5-0)+0$
4	80.0	$(100-0)*(4-0)\div(5-0)+0$
5	100.0	$(100-0)*(5-0)\div(5-0)+0$

As shown in the above formula, when measuring 2.5V, current DC0-5Vvoltage is 50%RH.

1. temperature and DC0-10Vvoltage computing relationship

For example, the range is 0~50℃, the analog output is 0~10V DC0-10Vvoltage signal, temperature and DC0-10Vvoltage The calculation relationship is as shown in the formula: $C = (A2-A1) * (X-B1) / (B2-B1) + A1$, where A2 is temperature range upper limit, A1 is the lower limit of the range, B2 is DC0-10Vvoltage output range upper limit, B1 is the lower limit, X is the currently read temperature val

DC0-10Vvoltage(V)	temperatureValue (℃)	Calculation Process
0	0.0	$(50-0)*(0-0)\div(10-0)+0$
1	5.0	$(50-0)*(1-0)\div(10-0)+0$
2	10.0	$(50-0)*(2-0)\div(10-0)+0$
3	15.0	$(50-0)*(3-0)\div(10-0)+0$
4	20.0	$(50-0)*(4-0)\div(10-0)+0$
5	25.0	$(50-0)*(5-0)\div(10-0)+0$
6	30.0	$(50-0)*(6-0)\div(10-0)+0$
7	35.0	$(50-0)*(7-0)\div(10-0)+0$
8	40.0	$(50-0)*(8-0)\div(10-0)+0$
9	45.0	$(50-0)*(9-0)\div(10-0)+0$
10	50.0	$(50-0)*(10-0)\div(10-0)+0$

ue, and C is the calculated DC0-10Vvoltage value. The list of commonly used values is as follows:

As shown in the above formula, when measuring 5V, current DC0-10Vvoltage is 25℃.

2. humidity and DC0-10Vvoltage computing relationship

For example, the range is 0~100%RH, the analog output is 0~10V DC0-10Vvoltage signal, humidity and DC0-10Vvoltage The calculation relationship is as shown in the formula: $C = (A2-A1) * (X-B1) / (B2-B1) + A1$, where A2 is humidity range upper limit, A1 is the lower limit of the range, B2 is DC0-10Vvoltage output range upper limit, B1 is the lower limit, X is the currently read humid

DC0-10Vvoltage(V)	humidityValue (%RH)	Calculation Process
0	0.0	$(100-0)*(0-0)\div(10-0)+0$
1	10.0	$(100-0)*(1-0)\div(10-0)+0$
2	20.0	$(100-0)*(2-0)\div(10-0)+0$
3	30.0	$(100-0)*(3-0)\div(10-0)+0$
4	40.0	$(100-0)*(4-0)\div(10-0)+0$
5	50.0	$(100-0)*(5-0)\div(10-0)+0$
6	60.0	$(100-0)*(6-0)\div(10-0)+0$
7	70.0	$(100-0)*(7-0)\div(10-0)+0$
8	80.0	$(100-0)*(8-0)\div(10-0)+0$

9	90.0	$(100-0)*(9-0)\div(10-0)+0$
10	100.0	$(100-0)*(10-0)\div(10-0)+0$

ity value, and C is the calculated DC0-10Vvoltage value. The list of commonly used values is as follows:

As shown in the above formula, when measuring 5V, current DC0-10Vvoltage is 50%RH。

Disclaimer

This document provides all information about the product, does not grant any license to intellectual property, does not express or imply, and prohibits any other means of granting any intellectual property rights, such as the statement of sales terms and conditions of this product, other issues. No liability is assumed. Furthermore, our company makes no warranties, express or implied, regarding the sale and use of this product, including the suitability for the specific use of the product, the marketability or the infringement liability for any patent, copyright or other intellectual property rights, etc. Product specifications and product descriptions may be modified at any time without notice.

Contact Us

Company: Shanghai Sonbest Industrial Co., Ltd INTOIOT Brand Division

Address: Building 8, No.215 North east road, Baoshan District, Shanghai, China

Web: <http://www.intoiot.cn>

Web: <http://www.intoiot.com>

SKYPE: soobuu

Email: sale@sonbest.com

Tel: 86-021-51083595 / 66862055 / 66862075 / 66861077